

audio research

Reference 80S

H I G H D E F I N I T I O N[®]

audio research
HIGH DEFINITION®

There is only One Reference®

Thank You.

Thank you for choosing the Reference 80S to be a part of your high performance music listening system. Since 1970, Audio Research has been creating some of the world's finest audio equipment. Each piece is handcrafted in Minnesota, and has been designed to provide many years of listening enjoyment.

We understand you are eager to begin listening; however, please take a few minutes to read through this guide for useful information concerning the operation of your new amplifier. Once installed, please allow an appropriate break-in period to fully appreciate the benefits this amplifier will provide to your system.

After reading the user guide, if you have any further questions regarding your amplifier, contact your dealer or Audio Research customer service - they will be happy to help you make the most of your new component.

Happy Listening!

Safety Instructions	5-6	
Warnings	7	
Installation		
8	8	Vacuum Tube Placement
8	8	Before Operating the Reference 80S
9	9	Tube Cage Removal
10	10	Tube Cage Installation
11	11	Ventilation Requirements
11	11	In Your System
11	11	Vacuum Tube Life Expectancy
Connections		
12	12	Back Panel Connections
12	12	Input Connectors
13	13	Output Connectors
13	13	Impedance Matching
13	13	Remote Turn On
14	14	RS-232
14	14	A.C. Power Connection
15	15	Back Panel Controls
Operation		
16	16	Front Panel Controls
17	17	Start Up
17	17	Shut Down
18	18	Front Panel Button Controls
19	19	Hour Counter
19	19	Break In
Maintenance		
20	20	Vacuum Tubes
20	20	Service
20	20	Cleaning
21	21	Disposal and Recycling Guidelines
Warranty	22	
Specifications	23	



The lightning flash with arrowhead symbol with an equilateral triangle, is intended to alert the user to the presence of uninsulated 'dangerous voltage' within the product's enclosure that may be of sufficient magnitude to constitute a risk of electric shock to persons.



The exclamation point within an equilateral triangle is intended to alert the user to the presence of important operating and maintenance (service) instructions in the literature accompanying the product.



The 3 wavy lines symbol within an equilateral triangle is intended to alert the user to the presence of a hot surface on the exterior case of the product.

- Read these instructions.
- Keep these instructions.
- Heed all warnings.
- Follow all instructions.
- Do not use this apparatus near water
- Clean only with dry cloth.
- Do not block any ventilation openings. Install in accordance with the manufacturer's instructions.
- Do not install near any heat sources such as radiators, heat registers, stoves, or other apparatus (including amplifiers) that produce heat.
- Do not defeat the purpose of the polarized or grounding-type plug. A polarized plug has two blades with one wider than the other. A grounding-type plug has two blades and a third grounding prong. The wide blade or the third prong are provided for your safety. If the provided plug does not fit into your outlet, consult an electrician for replacement of the obsolete outlet.

Safety Instructions

- Warning: The apparatus shall be connected to a mains socket outlet with a protective earthing connection.
- Protect the power cord from being walk on or pinched particularly at plugs, convenience receptacles, and the point where they exit from the apparatus.
- Only use attachments/accessories specified by the manufacturer.
- Unplug this apparatus during lightning storms or when unused for long periods of time.
- Refer all servicing to qualified service personnel. Servicing is required when the apparatus has been damaged in any way, such as power supply cord or plug is damaged, liquid has been spilled or objects have fallen into the apparatus, the apparatus has been exposed to rain or moisture, does not operate normally, or has been dropped.
- WARNING: TO REDUCE THE RISK OF FIRE OR ELECTRIC SHOCK, DO NOT EXPOSE THIS APPARATUS TO RAIN OR MOISTURE.
- DO NOT EXPOSE THIS APARATUS TO DRIPPING OR SPLASHING AND THAT NO OBJECTS FILLED WITH LIQUIDS, SUCH AS VASES, SHOULD NOT BE PLACED ON THE APPARATUS.
- TO COMPLETELY DISCONNECT THIS APPARATUS FROM THE AC MAINS, DISCONNECT THE POWER SUPPLY CORD FROM THE AC RECEPTABLE.
- THE MAINS PLUG OF THE POPWER SUPPLY CORD SHALL REMAIN READILY ACCESSIBLE.
- The user-replaceable rear panel fuse of the Reference 80S shall only be replaced with a fuse of the correct breaking capacity and voltage rating as specified below and on the rear panel of the amplifier.
 - 100-127V T5AL250V MDQ (ARC part 34500505)
 - 220-240V T2.5AL250V (ARC part 34600303)
- Speaker terminal banana jacks are plugged/capped for units sold in countries where this is required due to power cord plub pin shapre.

To prevent fire, or shock hazard, do not expose your Reference 80S to rain or moisture.

Do not place objects containing water on top of this unit.

This unit contains voltages which can cause serious injury or death. Do not operate with covers removed. Refer servicing to your authorized Audio Research dealer or other qualified personnel.

The detachable power cord on your Reference 80S is equipped with a heavy gauge, 3-conductor cable and a standard three-prong grounding plug. For absolute protection, do not defeat the ground power plug. This provides power line grounding of the Reference 80S chassis to provide absolute protection from electrical shock.

The appliance coupler (a.c. power connector) at the rear of this unit must be accessible for emergency power disconnect.

The power button on the front of this unit, when off, does not disconnect all power from this unit. This unit is in sleep mode when not on.

For continued protection against fire hazard, replace the fuse only with the same type and rating as specified at the fuse holder

This unit is RoHS compliant.

Handling and moving the Reference 80S

The Reference 80S weighs 62 lbs. (28 kg). When lifting, note the rear of the amplifier with the power and output transformers is the heavy end.

A note about packaging...

Save all packaging in a dry place away from fire hazard. Your Reference 80S preamplifier is a precision electronic instrument and should be properly cartoned any time shipment is made. You may not have occasion to return your unit to the factory for service, but if that should prove necessary, or other occasion requiring shipment occurs, the original packaging will protect your Reference 80S from unnecessary damage or delay.



Important

The AC power supply cord must be disconnected from the amplifier before replacement or installation of vacuum tubes.

Vacuum Tube Placement

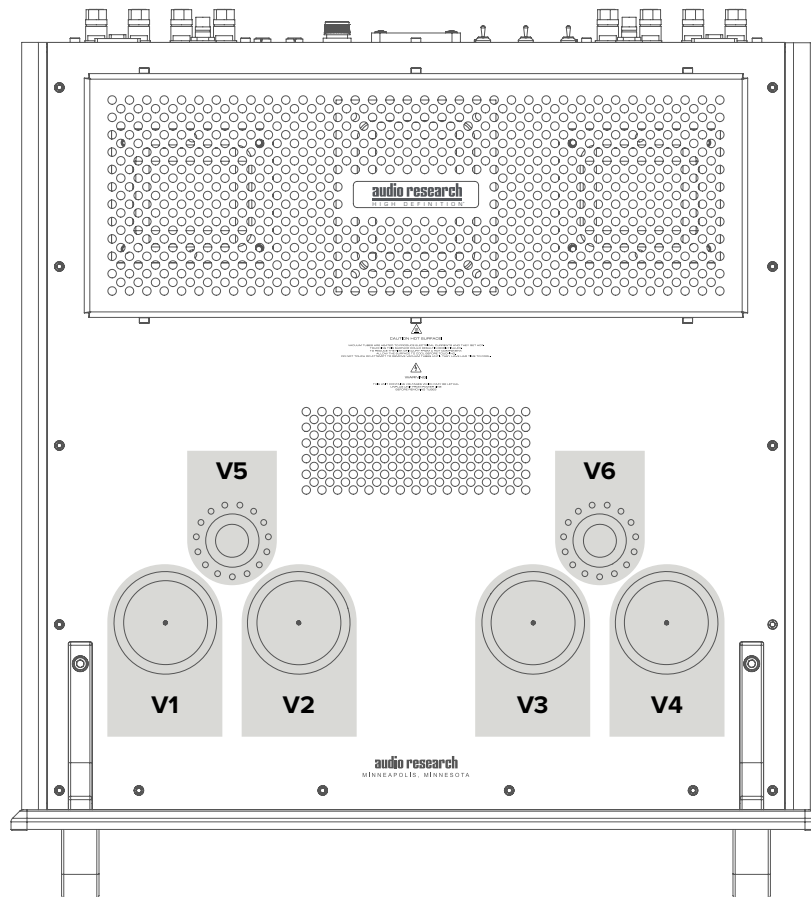

Before operating the Reference 80S

Your Reference 80S amplifier is shipped with the vacuum tubes packed in a separate foam-lined carton. These must be unpacked and installed before you attempt to operate the amplifier. Included are four matched KT150s and two matched 6H30 tubes.

Follow the procedure on the next pages to remove the top cage prior to vacuum tube installation.

Vacuum Tube Installation

Carefully remove each vacuum tube from its protective foam and match its location 'V' number (written on the base of the tube) to the 'V' number screened next to each socket on the top plate of the Reference 80S. Firmly seat each tube in its matching socket, taking care to align the key at the base of each KT150 to its socket hole.

The 6H30 tubes in V5 and V6 are not keyed, and care must be taken to align the pins to the sockets. A small flashlight can assist.

Tube cage removal and installation

CAUTION: THIS STEP FOLLOWED BY USER IS ALLOWED ONLY ONCE FOR THE INITIAL INSTALLATION BEFORE POWERING UP THE PRODUCT FIRST.

Warning: Tube replacement shall be done by skilled or service personnel, or qualified technician.



Important

The AC power supply cord must be disconnected from the amplifier before replacement or installation of vacuum tubes.

To remove the cage:

Use the supplied 7/64" hex driver to remove the (3) cap screws and nylon washers at the rear of the top cage, per illustration 1:

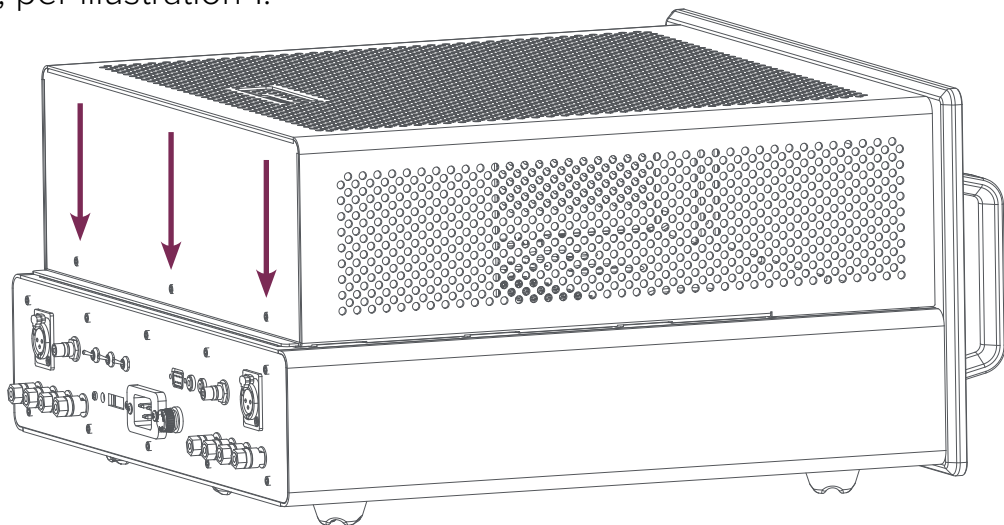

Illustration 1

Gently slide the cage to the rear. Then lift it up and off the chassis, per illustrations 2 and 3.

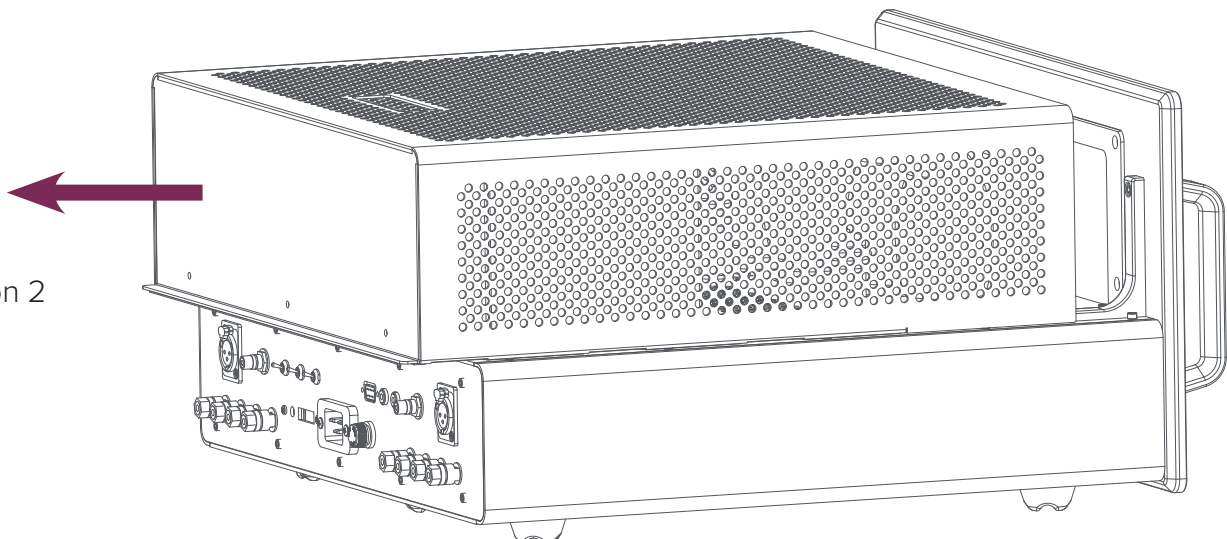
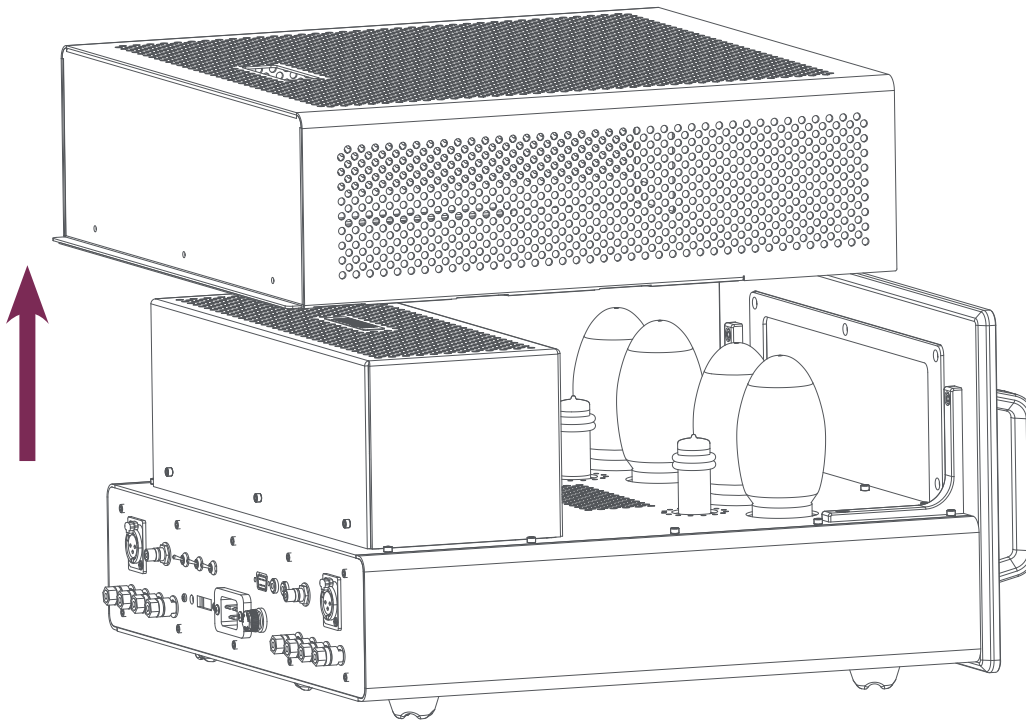

Illustration 2

Illustration 3



To install the cage:

Gently place the cage on top of the chassis. Ensure the sides of the cage are fully seated on the top plate.

Slowly slide the cage forward until the two locating screws engage with the cap screws behind the front panel.

See illustration 4. When the cage rear flange is flush with the rear edge of the chassis the cage is fully installed. Note that you may have to slightly squeeze in the sides to allow slots in the cage flange to align with the top plate cap screws.

Illustration 4

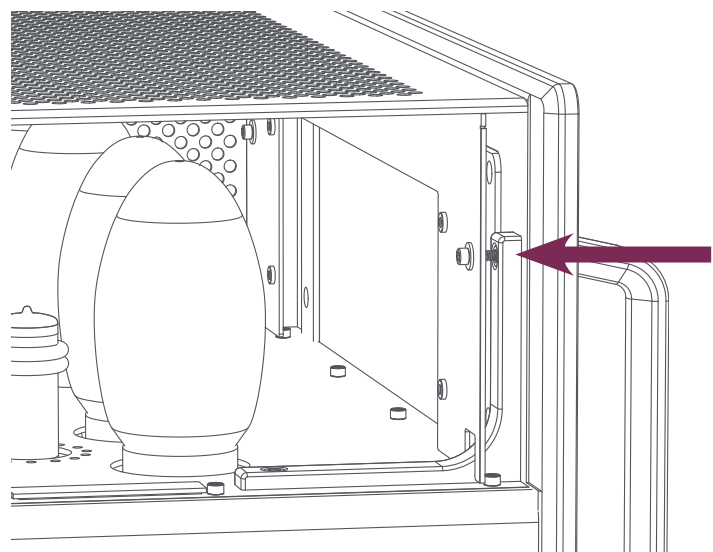

Ventilation Requirements

The Reference 80S employs forced air cooling using an ultra-quiet internal fan, located on the bottom cover near the front of the chassis. This fan draws cool air from under the unit, circulates the air internally to cool components, and exhausts the heated air from grilles on the chassis top plate and transformer cover. It is very important that cooling airflow to this fan not be impeded in any way by placing the unit on carpet or a soft surface that might allow the Reference 80S to settle into the surface and impede the airflow.

A minimum of 8 inches (21cm) clearance is required above the top of the amplifier. If the unit is operated in an enclosure or equipment rack, keep in mind the above ventilation requirements to make certain that adequate airflow above, to each side and to the rear is provided.

The ambient operating temperature should never exceed 86°F (30°C). Improper installation will cause premature component and /or tube failure and will affect your warranty as well as the service life of the unit. If you have any questions about correct installation, please consult with your authorized Audio Research dealer or contact the factory at service@audioresearch.com.

In Your System

To ensure normal component life and safe operation, this unit should only be operated in an upright position. The special non-marring elastomer feet

provide adequate spacing and stability only on a smooth, hard surface, and must be on a dedicated shelf or amp stand capable of supporting 62 lbs. Check with the manufacturer of your support system to be sure it is rated to handle this weight.

The Reference 80S power transformer generates a magnetic field that could, in some installations, induce hum in sensitive electronics such as turntables, phono cartridges and phono stage preamplifiers. For this reason, we recommend that any such products and their interconnecting cables be kept a minimum of 12" away from the Reference 80S.

Vacuum Tube Life Expectancy

The vacuum tubes in your Reference 80S have been burned in, tested and electrically matched to provide the best performance and reliability of your amplifier. That said, vacuum tubes wear out with use and must be periodically replaced. The KT150 output tubes in the Reference 80S should have an estimated life of approximately 3000 hours, while the smaller 6H30 tubes should have a life expectancy of approximately 4000 hours. These life expectancies are only approximate. Please consult with your dealer or Audio Research customer support for more information. Warning: Tube replacement shall be done by skilled or service personnel, or qualified technician.

Back Panel Connections

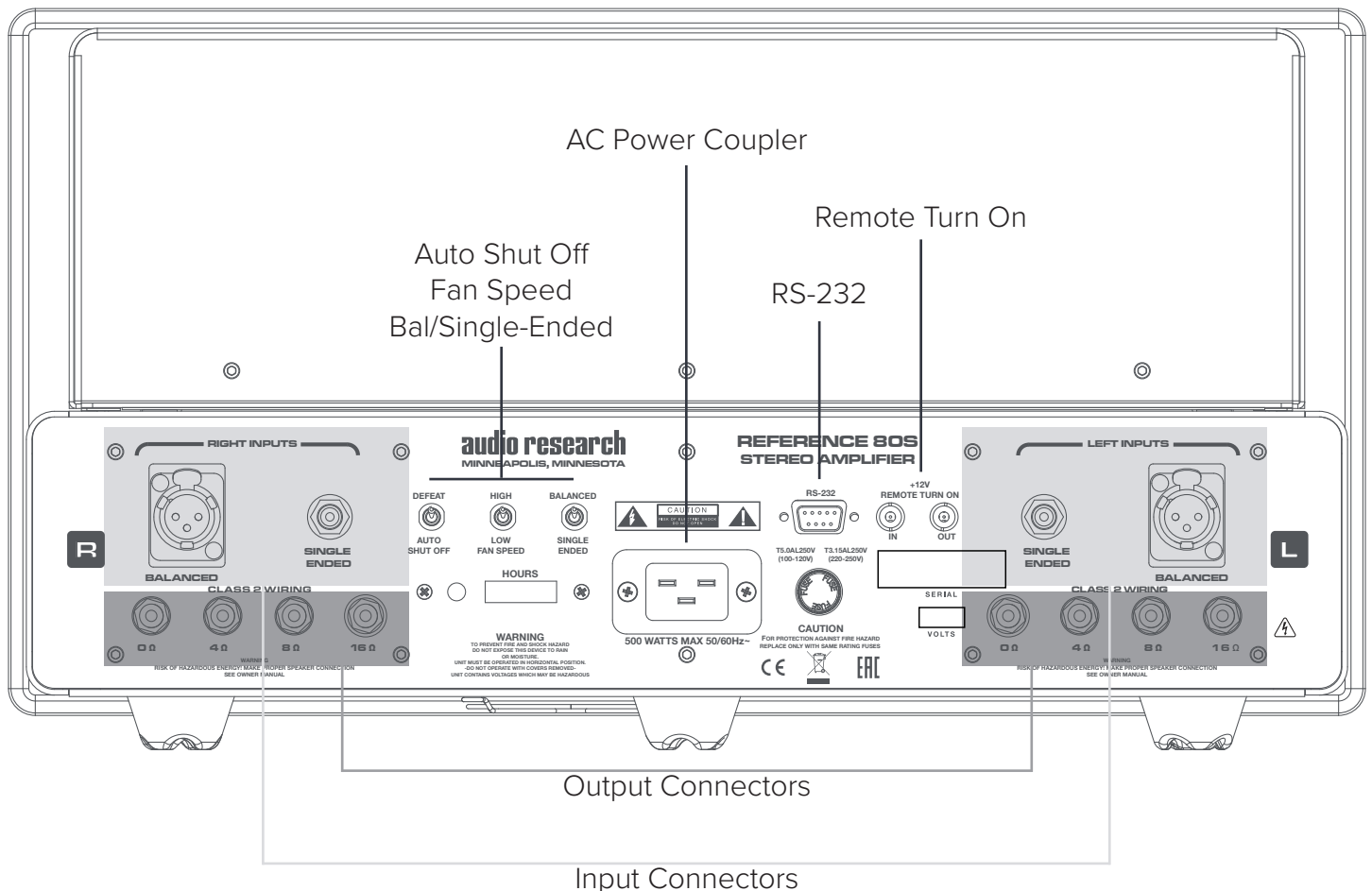

Input Connectors

The Reference 80S uses a fully balanced circuit topology and has a pair of balanced XLR input connectors and a pair of single-ended RCA input connectors on the rear panel. The rear panel switch must be in the appropriate labeled position for either balanced or single-ended use. Connect your preamplifier's output to the Reference 80S input connectors before turning on the amplifier.

Do not connect the balanced XLR input connectors and single-ended RCA input connectors at the same time – connect one pair or the other the same way for both channels.

Output Connectors

Heavy-duty output terminals are provided on the rear panel for 4, 8, or 16-ohm speaker impedance loads. Using high-quality speaker cables, securely fasten the (-) speaker lead to the appropriate (black) terminal, then the (+) lead to the matching (red) terminal. It is important sonically that your entire system be connected so that the audio signal arriving at the speakers has correct, or 'absolute' polarity (i.e., non-inverted). Do not over-tighten the output terminal connectors on the amp (use a hex driver and tighten snugly - do not over-tighten). Follow your speaker manufacturer's impedance specification. The Reference 80S puts out the same amount of power whether the 4, 8, or 16-ohm terminals are used.

Impedance Matching

It is important to use as close as possible an impedance match between the amplifier and speaker for optimum transfer of power to the speaker with minimum distortion. In the case of speaker systems with significant variations in impedance throughout the frequency spectrum, such as most electrostatic types, determine the best impedance match empirically for best overall sonic results by trying different output taps. Connect the Reference 80S input to the preamplifier or electronic crossover using only the highest grade of audio interconnect cables. To avoid sonic degradation use the shortest practical length of cables.

Important

Use the best available speaker wires and interconnects. Audio Research cannot emphasize this enough. As better components and systems are developed, it becomes increasingly important to avoid the limitations of inferior system interconnections.

Remote Turn-on

The Reference 80S has a built-in 12V DC remote turn-on/off circuit for operation by a master control system in a home theater or large audio system. Use a 3.5mm (.140") diameter mini plug to connect to the +12V IN jack on the rear of the Reference 80S. The tip of the mini plug is +12V and the sleeve is ground.

The +12V IN jack should be connected to the +12V DC output of the master control system, using a continuous +12V DC signal at 12mA for the duration of amplifier on-time. Do not use a momentary or data pulse control signal.

The +12V DC remote jacks have polarity protection, so they will not operate if a -12V DC signal is accidentally connected, or if the control wires are reversed.

RS-232 Control

The Reference 80S has an RS-232 connector on the back panel, in the event the amplifier is incorporated into an automated or two-way remote communication system. Please see your dealer or contact service@audioresearch to acquire specific codes relative to the RS-232 control.

A.C. Power Connection

It is important that the Reference 80S be connected via its supplied 20 amp IEC 12-gauge power cord to a secure, dedicated A.C. power receptacle. Never connect to convenience power receptacles on other equipment. Only use the power switch on the front of the Reference 80S for On/Off control of the amplifier, or the 12V start-up trigger or RS-232 for remote installations.

The AC power source for the Reference 80S amplifier should be capable of supplying 15 amperes for 100 or 120 volt units, or 10 amperes for 220 or 240 volt units.

For the very best performance, the Reference 80S should be connected to its own AC power circuit branch, protected by a dedicated circuit breaker. The preamplifier and other audio equipment should be connected to a different power circuit and breaker, if possible.

The Reference 80S uses a grounding system that does not require a ground lifter adapter plug on the A.C. power cord to minimize hum. The power cord supplied with the Reference 80S has a standard grounding plug to provide maximum safety when properly connected to a grounded wall receptacle. If there is any question regarding proper grounding procedures in your installation, seek help from a qualified technician. Caution should be taken before using custom after-market power cords: they must be at least 12-gauge and have a standard grounding plug properly installed. These power cords are to be used with caution, at the sole risk of the owner. If electronic crossovers or other AC powered equipment is used with the Reference 80S it may be necessary to use 'ground lifter' adapters on the power plugs of that equipment to minimize system hum. Generally, the lowest hum is achieved when the only direct connection between audio common 'ground' and true earth ground occurs in the preamplifier, through its grounded power cord. Other equipment in the system should have some form of isolation to prevent ground loops and associated hum.

Back Panel Controls

High/Low Fan Speed

Allows adjusting fan speed to either low or high-speed setting.

Balanced/Single Ended

Select balanced switch position for balanced input connection operation or single-ended switch position for single-ended input connection operation.

Do not connect BAL and SE cables simultaneously. (See Input Connectors paragraph under Connections section for further information.)

Auto Shut Off/ Defeat

Allows selecting auto shut-off feature or turning off this feature (see separate Auto Shut Off paragraph under this Operation section for a more detailed description of this function).

About Auto Shut Off

The Reference 80S auto shut-off feature is designed to turn the amplifier off after two hours of no signal being present at the output of the amplifier.

In the event that quiet music is listened to at very low volumes, there may not be adequate signal for the auto shut off circuit, resulting in the amplifier turning itself off. If this is the case, please disengage the auto shut off feature.

The auto shut off feature control switch is located on the back panel of the Reference 80S.

Note

The auto shut off feature is not in the signal path of the amplifier and has no deleterious sonic effect on music playback.

Front Panel Controls

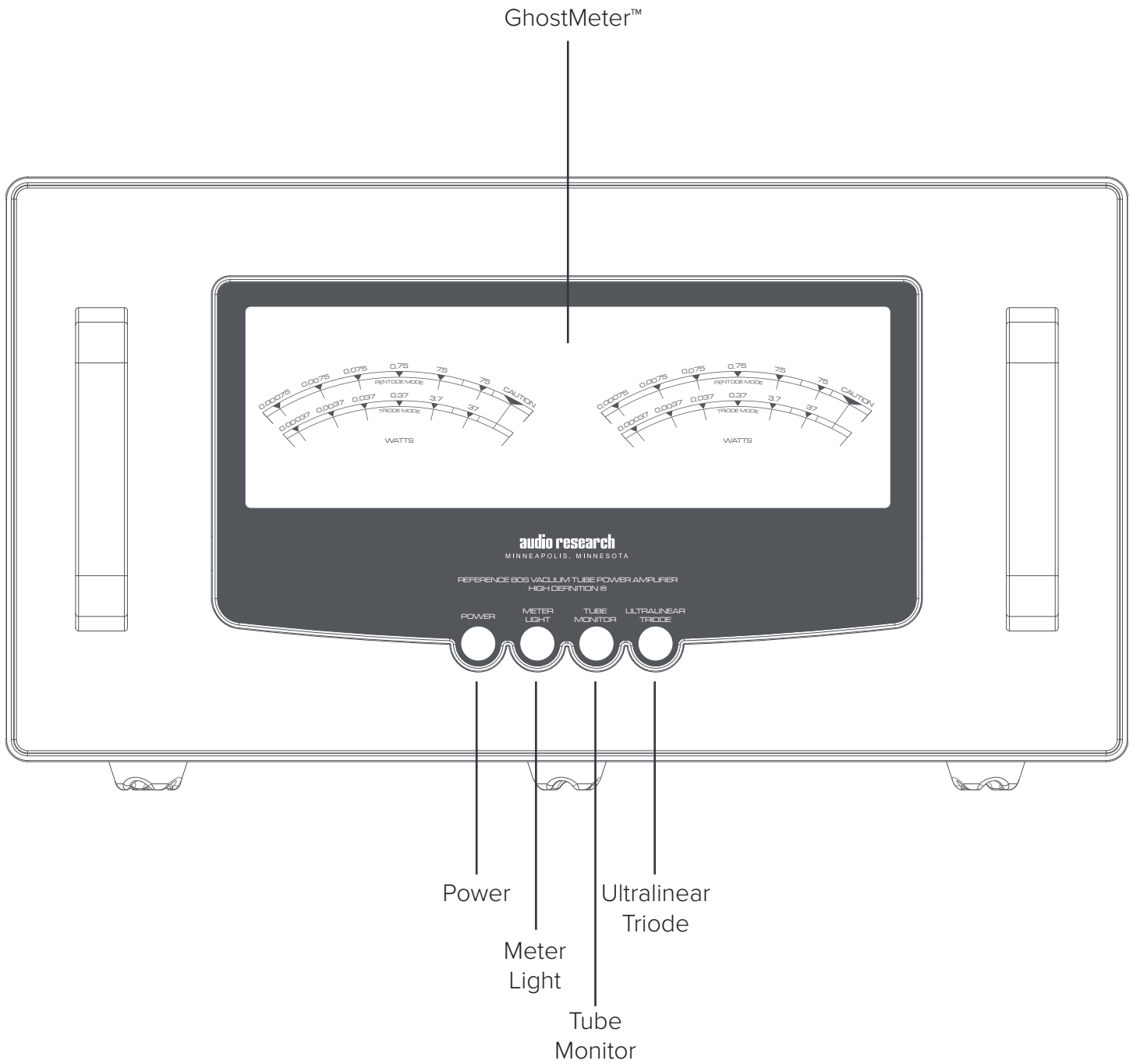

Start-Up

- Secure interconnects between the amplifier and your preamplifier to the appropriate output terminals.
- Attach supplied power cord to rear IEC inlet of amplifier, and plug other end into grounded A.C. power receptacle.
- Turn on preamp and all other components; mute preamp output.
- Press Reference 80S front panel power switch. Green power LED will flash on/off for approximately 2 minutes during the auto mute cycle to allow the amplifier to stabilize voltage before becoming active. The LED will stay on brightly, once the amplifier has stabilized.
- Unmute preamplifier output, initiate source component signal, and adjust gain as appropriate.

Note

The Reference 80S should be turned on after the other components of your system. If the Reference 80S is turned on before other components, the amplifier will amplify any extraneous turn-on noises those components might generate, which could potentially damage loudspeakers. Good practice dictates that the amplifier should be turned on last and turned off first in an audio system.

Shut-Down

- Mute preamplifier output.
- Turn off Reference 80S via front panel power switch (or 12V trigger or RS-232).

Note

To prevent stress to the power supply and vacuum tubes, the control circuitry is programmed with a “hot restart” lockout to prevent turning the unit on within 2 minutes of shutting the unit off. If the Reference 80S power switch is pressed during this lockout period, the power LED will illuminate red to indicate lockout operation. After 2 minutes, normal turn on can be initiated.

Power

Turns power of Reference 80S on or off.

GhostMeter™ Light

Adjusts meter light LED display brightness to one of four levels of brightness including “off”.

Tube Monitor

Allows checking the operation of each of the four KT 150 output tubes (V1-V4). The LED associated with each output tube will illuminate when operating properly. See Auto Bias section under Operation for further explanation of its operation.

Pentode/Triode

Allows selecting pentode (approximately 70 watts per channel) operation – indicated by green color of LED above this function button, or triode (approximately 35 watts per channel) operation – indicated by blue white color of the power-on LED.

Auto Bias

The Reference 80S incorporates a highly sophisticated auto-bias circuit. There are no user-adjustable bias controls. There should never be a need to check or adjust the auto-bias circuit: once it is factory set, no additional adjustment is required. The auto-bias circuit will ‘lock in’ the idle current of each bank of two KT150 output tubes approximately two minutes after the Reference 80S is turned on, and continually compensates to maintain the proper bias as the tubes age. Auto-bias sets the idle current at 65mA per tube.

It is always recommended owners purchase replacement tubes from Audio Research Corp. While the auto bias adjusts the idle current of each of the four KT150 output tubes, matched tube sets will provide optimum performance and longest tube life.

The auto bias circuit will not accommodate output tubes with extremely high or low plate current readings. Aftermarket tubes may not be tested to the same rigorous standards as Audio Research tests, so care must be exercised when installing aftermarket tubes. If uncertain about aftermarket tube requirements, please contact service@audioresearch.com for recommendations. Audio Research supplies the KT150 output tube in the Reference 80S, providing the highest power and best sound possible in this amplifier design.

Audio Research has tested the Reference 80S with KT120, KT88 and 6550WE output tubes. The Reference 80S will produce less power with any of these tubes and the sound will be degraded. Under no circumstances should any tube not electrically equivalent to the KT150, KT88 or 6550WE be installed. Tubes such as the EL34, KT77, 6L6 should never be installed. Installing tubes such as these will void the factory warranty and Audio Research will not be liable for any damage. Contact service@audioresearch.com if you have questions regarding tube compatibility.

Hour Counter

An LCD hour counter of elapsed tube operating time can be viewed on the back panel. This displays accumulated hours of vacuum tube service life. If the amplifier is unplugged from A.C. supply, the total accumulated hours are retained. Next to the hour counter is a recessed hour counter reset button; after replacing vacuum tubes, press this button to reset the hour counter back to zero. Note that once the hour counter has been reset, it is no longer possible to recall the previous hour count.

Break-in

All quality stereo equipment benefits from a break-in period; during this time, the various components, wiring and solder connections change as electrical signals pass through them. While your Reference 80S will sound very good out of the box, it will only improve with continued use.

Vacuum Tubes

It is recommended that you replace the vacuum tubes of your Reference 80S in sets. All of the tubes in your amplifier have been matched to have similar operating characteristics, to provide the best sound quality and reliability. In the event you need to replace a single output tube, please refer to the numbers written on the silver base at the bottom of the vacuum tube when placing an order. KT150 tubes should be replaced at approximately 3000 hours. 6H30 tubes should be replaced before 4000 hours.

Servicing

Because of its careful design and exacting standards of manufacture, your Reference 80S amplifier should normally require only minimal maintenance to maintain its high level of performance.

Should you need service, please contact your authorized Audio Research dealer or other qualified technician. Additional questions regarding the operation, maintenance or servicing of your amplifier, please contact the Customer Support Department of Audio Research Corporation at service@audioresearch.com or call 763-577-9700. You may also initiate a service request by visiting the Audio Research website (www.audioresearch.com) and selecting 'Service Repair' found under 'Support' at the top right of the home page.

Caution

Your Reference 80S preamplifier contains sufficient levels of voltage and current to be lethal. Do not tamper with a component or part inside the unit. Even with the power turned off, a charge remains in the energy storage capacitors for some time.

Cleaning

The Reference 80S uses one bottom-cover-mounted ultra-quiet fan for forced air cooling of internal components. Over time, depending upon the environment in which the Reference 80s is installed, dust will build up inside the chassis that may impede proper cooling, which could reduce component life. Audio Research therefore strongly recommends the owner have the Reference 80S cleaned of internal dust buildup either every two years of operation, or when the vacuum tube sets are replaced –whichever occurs first. Please contact your authorized Audio Research dealer, service center, or service@audioresearch.com for instructions and assistance with this cleaning operation.

To maintain the new appearance of this amplifier, occasionally wipe the aluminum front panel with a soft damp (not wet) microfiber cleaning cloth to remove dust. A mild non-alkaline soap solution may be used to remove fingerprints or similar smudges. To clean the GhostMeter™ panel, use moist disposable eyeglass wipes designed for coated plastic lenses. Do not apply pressure with a dry cloth. Cleaners containing abrasives should not be used as they will damage the anodized finish of the front panel and the GhostMeter™ panel.



Disposal and Recycling Guidelines

To dispose of this electronic product, do not place in landfill. In accordance with the European Union Waste Electrical and Electronic Equipment (WEEE) directive effective August 2005, this product may contain regulated materials which upon disposal require special reuse and recycling processing.

Please contact your dealer or importing distributor for instructions on proper disposal of this product in your country. Or, contact Audio Research Corporation (763.577.9700) for the name of your importing distributor and how to contact them. Packing and shipping materials may be disposed of in a normal manner.

Audio Research Corporation products are covered by a 3-Year Limited Warranty or a 90-Day Limited Warranty (vacuum tubes). This Limited Warranty initiates from the date of purchase, and is limited to the original purchaser, or in the case of demonstration equipment, limited to the balance of warranty remaining after original shipment to the retailer or importer.

In the United States, the specific terms, conditions and remedies for fulfillment of this Limited Warranty are listed on the warranty card accompanying the product in its shipping carton. The warranty terms are also available on the internet at www.audioresearch.com/en-us/company/warranty-statement. Outside the United States, the authorized importing retailer or distributor has accepted the responsibility for warranty of Audio Research products sold by them.

The specific terms and remedies for fulfillment of the Limited Warranty may vary from country to country. Warranty service should normally be obtained from the importing retailer or distributor from whom the product was purchased.

In the unlikely event that technical service beyond the ability of the importer is required, Audio Research will fulfill the terms and conditions of the Limited Warranty. Such product must be returned at the purchaser's expense to the Audio Research factory, along with a photocopy of the dated purchase receipt for the product, a written description of the problem(s) encountered, and any information necessary for return shipment. The cost of return shipment is the responsibility of the purchaser.

Audio Research Corporation does not warrant compatibility of Audio Research products with future operating systems and/or hardware of other manufacturers.

Power Output: 70 watts continuous from 20Hz to 20kHz. 1kHz total harmonic distortion typically 1% at 140 watts (33 watts in Triode mode) per channel, below 0.04% at 1 watt (Note that actual power output is dependent upon both line voltage and “condition” i.e.: if power line has high distortion, maximum power will be affected adversely, although from a listening standpoint this is not critical)

Power Bandwidth: (-3dB points) 7Hz to 68kHz

Frequency Response: (-3dB points at 1 watt) 0.7Hz to 94kHz

Input Sensitivity: 1.4V RMS Balanced for rated output. (25.5 dB gain into 8 ohms);
0.7V RMS SE for rated output.

Input Impedance: 300K ohms Balanced, 75K ohms Single Ended

Output Polarity: Non-inverting. Balanced input pin 2+ (IEC-268)

Output Taps: 16 ohms, 8 ohms, 4 ohms

Output Regulation: Approximately 1.0dB 16 Ohm Load to Open Circuit
(Damping factor approximately 8)

Overall Negative Feedback: 15dB

Slew Rate: 10 volts/microsecond

Rise Time: 4.0 microseconds

Power Requirements: 105-130VAC 60Hz (210-250VAC 50Hz) 420 watts at rated output,
280 watts in Triode mode, 221 watts at “idle”, 3.6 watts off Units for Japan: 100VAC 50/60Hz

Tubes Required: 2 matched pair KT150 (Power output V1-V4); 2 6H30 (Gain stage V5, V6)

Dimensions:

Width 18.5” (47 cm) chassis; 19.0” (48.26 cm) faceplate.

Height 10.5” (26 cm)

Depth 18.5” (47 cm)

With handles & connectors: 21” (53.3 cm)

Weight: 62 lbs. (28.2 kg) Net; 73 lbs. (32.7 kg) Shipping.



6655 Wedgwood Road North
Maple Grove, MN 55311

www.audioresearch.com

Specifications subject to change without notice.

©2020 Audio Research Corporation. Reproduction of this document in part or whole is expressly forbidden without written consent from Audio Research Corporation.